

GFM-C Series

GFM-800C 2V 800Ah

GFM-C series VRLA battery uses latest AGM technology, high purity raw materials and many patented technologies that ensure its long floating and cycle life, it is applicable to less frequency of power failure, and shallow discharge of depth site. It is mainly used for indoor telecommunication base station.

Benefits

- Long life according to EUROBAT Classification
- High discharge performance
- 99%+ gas recombination efficiency
- Maximum charge efficiency
- Low self-discharge rate
- Horizontal installation



Applications

- Telecommunications
- Power system
- UPS
- Emergency power

Drawing

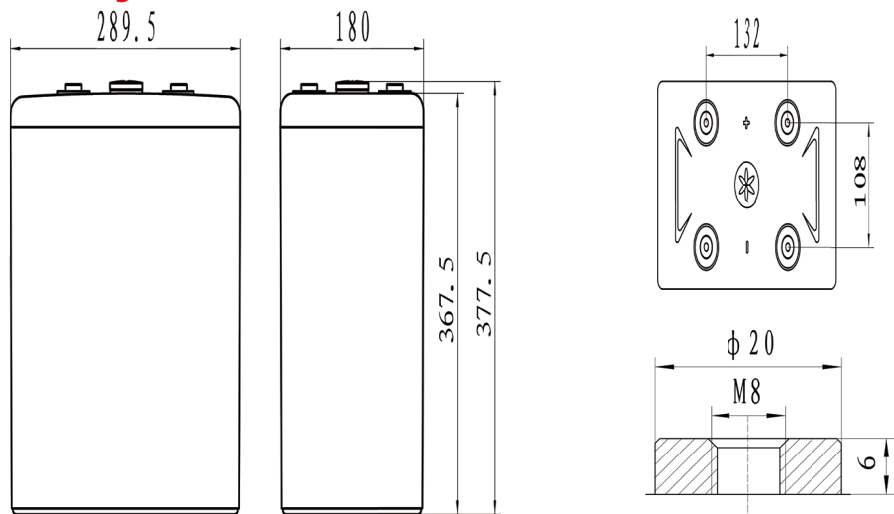

Specifications

Battery Model	GFM-800C			
Design Life (years, 25°C)	15			
Capacity (Ah, 25°C)	10HR (80A, 1.80V)	5HR (136A, 1.80V)	3HR (200A, 1.80V)	1HR (440A, 1.75V)
	800	680	600	440
Dimensions (mm)	Length	Width	Height	Total Height
	289.5	180	367.5	377.5
Approx. Weight (kg)	46.0			
Reference Internal Resistance (mΩ)	0.34 (fully charged @ 25°C)			
Maximum Discharge Current (A/5 Sec.)	2800			
Self-Discharge (25°C)	≤ 1.5% per months			
Charge Voltage (V/cell, 25°C)	Cycle use		Float use	
	2.35 (-3.5mV/°C/cell), max charge current: 120A		2.25 (-3.5mV/°C/cell)	
Short Circuit Current (A)	7200			

Discharge Data

Constant Current Discharge Data (25°C, A)															
End Voltage (V/cell)	min							h							
	5	10	15	20	30	40	50	1	1.5	2	3	5	8	10	24
1.60	1216	1120	1048	944	768	704	600	544	426	314	232	158	109	88.0	38.7
1.65	1136	1048	976	880	712	640	560	512	392	301	224	152	106	86.4	38.1
1.70	1032	944	864	800	656	584	528	480	365	288	216	146	102	84.5	37.4
1.75	936	832	752	688	600	536	480	440	336	272	208	141	99.2	82.4	36.3
1.80	800	736	672	624	544	488	440	400	314	256	200	136	96.0	80.0	35.4

Constant Power Discharge Data (25°C, W/cell)															
End Voltage (V/cell)	min							h							
	5	10	15	20	30	40	50	1	1.5	2	3	5	8	10	24
1.60	2085	1942	1830	1656	1356	1250	1069	973	766	569	425	293	204	166	74.2
1.65	1989	1855	1739	1575	1283	1158	1018	933	717	556	417	286	201	165	73.8
1.70	1845	1705	1569	1459	1205	1078	978	892	682	542	409	278	198	164	73.3
1.75	1707	1532	1393	1279	1123	1008	905	832	638	520	400	273	193	161	71.6
1.80	1481	1376	1263	1178	1032	930	841	766	602	495	388	265	188	157	70.0

Rack Layout

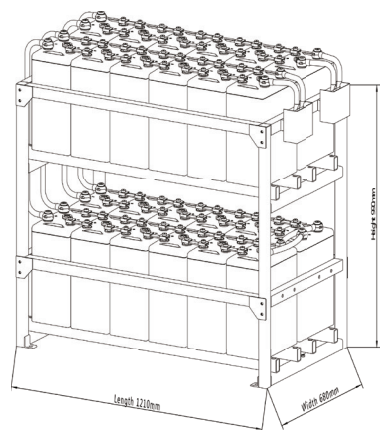

48V Standard Rack (Anti-seismic rack is optional)
 Rack material: powder-coated steel
 Height*width: 2*2
 Ref. GFM-800C Rack (approx. weight: 1164kg)

Performance Curve

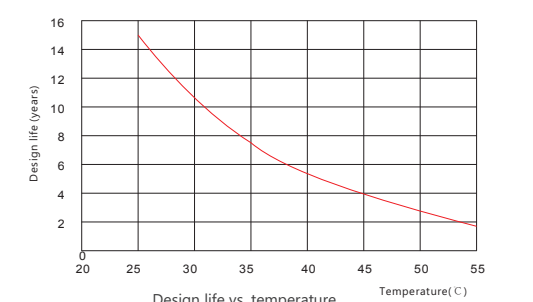
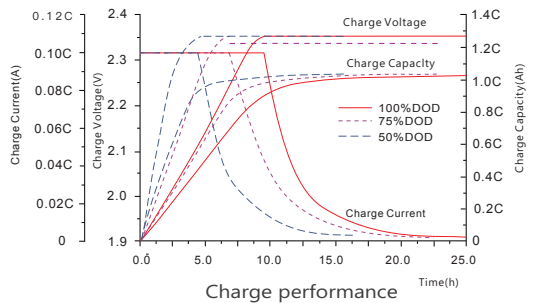
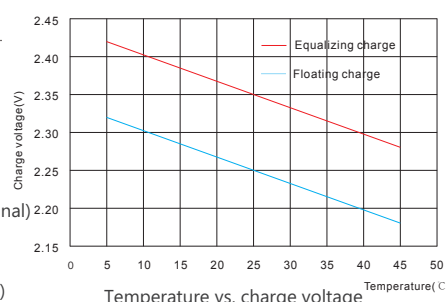
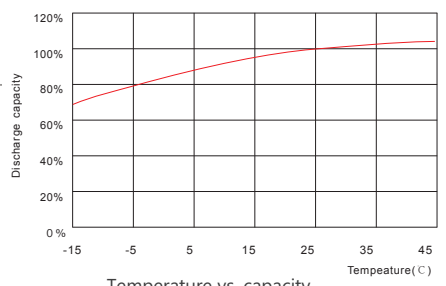

Sacred Sun Power Sources Co., Ltd.

No.1 Shengyang Road Qufu City, PRC
 sales@sacredsun.cn

Sacred Sun Asia Pacific

No. 15, Yishun Industrial Street 1,
 #01-17, WIN5, Singapore 768091
 sales.asia@sacredsun.cn

Sacred Sun Europe SPRL

Schoenstraat 96-9140 Temse, Belgium
 sales.eu@sacredsun.cn

Sacred Sun MEA FZE

S10122A1019 Jebel Ali, Dubai,
 United Arab Emirates
 sales.mea@sacredsun.cn

