

# FT Series

## FTA12-190 12V190Ah

Sacred Sun front terminal batteries have been designed specifically for applications which demand the highest levels of security and reliability. The monoblocs have excellent high rate performance, compact design and standard footprint for 19" and 23" cabinets. Thick Pb-Ca-Sn alloy grids are designed to resist corrosion and prolong service life.



### Benefits

- Long life according to EUROBAT Classification
- High discharge performance
- High gas recombination efficiency
- Maximum charge efficiency
- Low self-discharge rate
- Easy installation and handling
- Centralized venting system

### Applications

- Telecommunications
- Power system
- UPS
- Emergency power
- Data center

### Standards

- IEC 60896-21/22
- BS 6290-4
- EUROBAT guide
- Installation compliant with EN50272-2

### Drawing

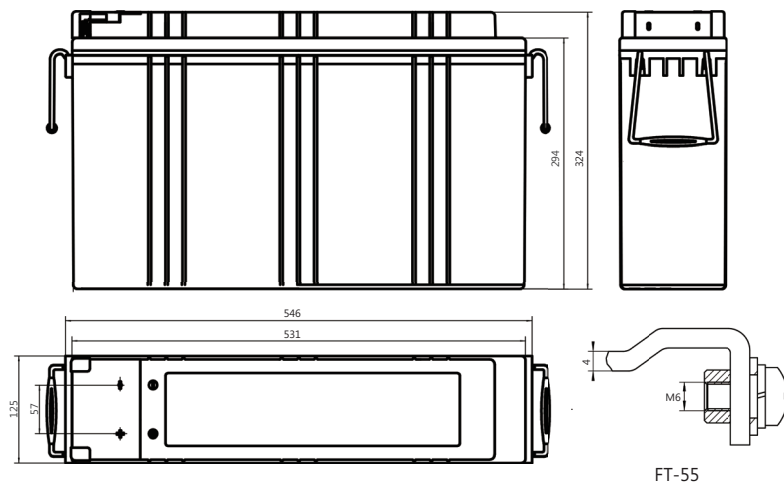

### Specifications

Battery Model	FTA12-190			
Design Life (years, 25°C)	12			
Capacity (Ah, 25°C)	10HR (19.0A, 1.80V)	5HR (33.8A, 1.80V)	3HR (49.7A, 1.80V)	1HR(106.1A, 1.75V)
	190	169	149.1	106.1
Dimensions (mm)	Length	Width	Height	Total Height
	546	125	324	324
Approx. Weight (kg)	58.0			
Reference Internal Resistance (mΩ)	4.1 ( fully charged @ 25°C)			
Maximum Discharge Current (A/3 Sec.)	1500			
Self-Discharge (25°C)	≤ 1.5% per month			
Charge Voltage (V/cell, 25°C)	Cycle use		Float use	
	2.35 (-3.5mV/°C/cell), max charge current: 38A		2.25 (-3.5mV/°C/cell)	
Short Circuit Current (A)	3750			

## Discharge Data

Constant Current Discharge Data (25°C, A)														
End Voltage (V/cell)	min					h								
	5	10	15	30	45	1	2	3	4	5	6	8	10	20
1.60	506.0	385.7	306.6	198.3	141.3	116.3	75.4	53.70	43.8	35.30	30.10	23.40	19.60	10.60
1.65	490.5	374.4	300.5	190.0	139.6	112.5	73.7	52.10	43.1	34.90	30.10	23.30	19.4	10.50
1.70	450.9	346.0	290.1	186.0	138.3	108.9	71.8	51.20	42.3	34.60	29.70	23.00	19.3	10.30
1.75	415.6	317.1	274.0	183.0	137.8	106.1	70.7	50.60	41.6	34.20	29.40	22.80	19.10	10.25
1.80	370.7	294.6	262.4	163.9	123.7	98.3	68.7	49.70	41.3	33.80	29.10	22.50	19.0	10.20

Constant Power Discharge Data (25°C, W/cell)														
End Voltage (V/cell)	min					h								
	5	10	15	30	45	1	2	3	4	5	6	8	10	20
1.60	882.6	710.2	570.0	412.5	295.2	237.8	150	110.0	83.8	67.50	57.90	44.90	32.65	20.40
1.65	844.0	668.4	550.0	389.3	290.6	231.4	147.8	107.0	82.7	67.20	57.70	44.70	32.5	20.30
1.70	802.2	622.3	520.0	387.0	283.0	220.7	144.6	104.0	81.6	66.90	57.40	44.40	32.2	20.10
1.75	756.3	583.7	483.0	384.0	276.8	216.4	143.6	103.0	80.7	66.40	57.00	44.20	32.00	19.90
1.80	703.7	562.3	473.0	340.0	249.1	208.9	140.3	100.0	80.3	65.70	56.60	43.90	31.8	19.80

## Performance Curve

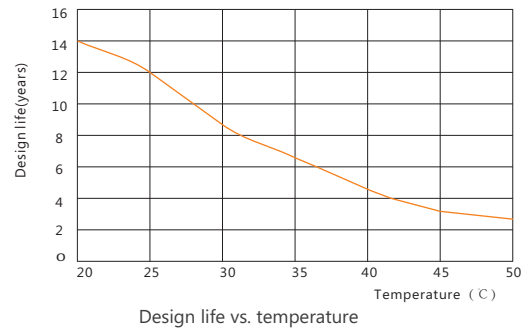
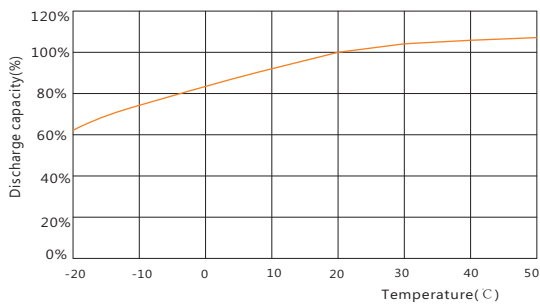
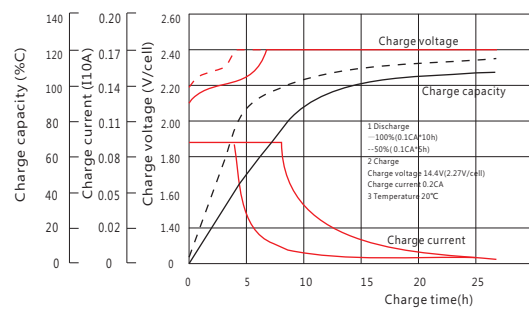
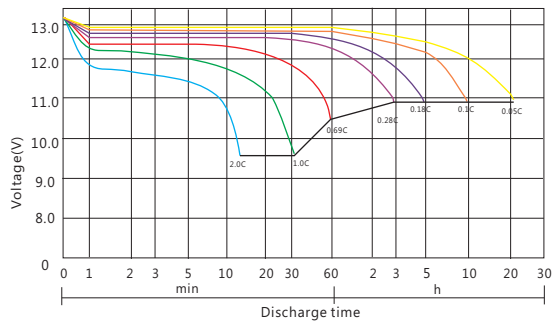

### Sacred Sun Power Sources Co., Ltd.

No.1 Shengyang Road Qufu City, PRC  
sales@sacredsun.cn

### Sacred Sun Asia Pacific

No. 15, Yishun Industrial Street 1,  
#01-17, WIN5, Singapore 768091  
sales.asia@sacredsun.cn

### Sacred Sun Europe SPRL

Schoenstraat 96-9140 Temse, Belgium  
sales.eu@sacredsun.cn

### Sacred Sun MEA FZE

S10122A1019 Jebel Ali, Dubai,  
United Arab Emirates  
sales.mea@sacredsun.cn

